

OPERA Inc.

6000 Series

Digital Gas Monitor/Controller

OPERATION MANUAL



TABLE OF CONTENTS

- 1.0 General Description
 - 1.1 Applications
 - 1.2 Features
 - 1.3 Specifications
 - 1.4 User Interface
- 2.0 Model Selection Guide
- 3.0 Installation
 - 3.1 Monitor Placement
 - 3.2 Wiring
 - 3.3 Installation Check List
- 4.0 Operation
 - 4.1 Screen Display
 - 4.2 Default Settings
 - 4.3 Changing Settings
 - 4.4 List of Settings
 - 4.5 Sequence of Operation
- 5.0 Network Configuration
 - 5.1 Using CAN Network, Central Controller
 - 5.2 Using CAN Network No Central Controller
 - 5.3 Defaults Configuration
 - 5.4 Creating Zones or Groups
 - 5.5 Addresses
 - 5.6 Output Relays
- 6.0 Maintenance Guide
 - 6.1 Calibration Procedure
- 7.0 BACnet Network Configuration

Important Information !

This manual provides information required to install, operate and maintain the series 6000 gas monitoring system. Read and study before attempting to install or operate monitors. Installation and operation not in accordance with this manual can result in a hazardous situation or harm. Relay connections may be used to control 120 Vac equipment. Ensure power is disconnected from relays before attempting to service this unit.

1.0 General Description

Series 6000 gas monitors provide air quality monitoring for commercial properties. Close monitoring of indoor air-borne pollutants and automatic fresh air controls improve the health and well being of occupants and, also minimize excess ventilation, reducing both energy costs and maintenance costs. The key to maintaining this balance is a high level of precision coupled with a robust design suited to tough commercial applications.

Each 6000 monitor can measure one or two gases and control ventilation directly. They communicate with each other (up to 32) via the chain network, so some monitors activate the ventilation and others send the commands. The monitors are easily assigned to groups on site for ventilation zoning on the same network. This reduces control wiring significantly.

The use of this peer-to-peer CAN network eliminates the need for a costly controller on smaller projects. For the larger ones, a 6000-B controller or addressable relay units can be added where starters are centralized in the mechanical room. The monitors can also be tied into a BACnet building automation system by simply connecting an MS/TP cable to any monitor or 6000 controller on the CAN network. The gas readings from all the monitors will display on the BMS and the BMS can over-ride output relays on the monitor it is connected to.

1.1 Applications:

- Vehicle emissions in indoor parking garages
- Municipal maintenance facilities
- Bus terminals
- Automobile dealerships
- Hospital parking for ambulances and visitors
- Volatile organic vapor control from soil contamination
- Refrigerant Gas Leak Monitoring
- CO2 demand control ventilation for meeting rooms
- Warehouse ventilation Control

1.2 Features:

- Stand-alone operation with adjustable alarm relays, indicators and strobe
- BACnet Laboratory (BTL) listed Smart Sensor
- BACnet MS/TP RS485 interface
- CAN network master-slave operation or central control via 6000-B controller.
- Pre-calibrated plug-and-play sensor modules avoid the need to recalibrate when upgrading expired sensors.
- Impact resistant, water resistant enclosure, with top wire entry and drip proof wire guide.
- Binary input for confirmation of external action (fan on or damper open)

1.3 Specifications

- Supply 24 vac 50/60 hz 0.21 amps, 5 va
- Relays (1 or 2) SPDT, 5 amp @ 125 vac, non-inductive
On delay; 0-999 seconds (16 minutes)
Off delay; 0-999 seconds (16 minutes)
- Operating temperature -20 °C to 40 °C (-4 °F to 104 °F)
- For indoor use
- Flame resistant Polycarbonate ABS enclosure rated UL94 V0, 5VB, and 5VA
- Standards. Listed to CSA C22.2. no. 205-17.
Conforms to CSA C22.2 61010-1.
- Analogue 4-20 ma or 2-10v (model 6000-A)

- Pollution degree 2
- Installation category II
- Altitude 2000 m
- Humidity max 80% rh. 80% to temperatures up to 31 °C 88 °F, decreasing linearity to 50% rh at 40 °C (104 °F)

1.4 User Interface:

- Back lit LCD display shows gas concentration, user settings, calibration controls
- Red LED alarm indicators, gas level 1 and 2
- High intensity white LED strobe on level 3
- Audible alarm, 85 db at 1 meter
- 4 pushbutton user keypad
- Password control for settings

2.0 Model Selection Guide



Controller Only

6000-B

- 2 relays
- no analogue outputs

6000-A

- 1 relays
- 2 analogue outputs



Controller with
Sensor(s) inside

Example: Monitor for CO + NO₂

6002-14-B

└ Gas Type
(see chart)

└ Gas type
if second
sensor
installed

6002-14-A

└ Gas Type
(see chart)

└ Gas type
if second
sensor
installed



Sensor Replacement
Module

55-xx

└ Gas Type
(see chart)

		Gas Type	Range
-	Controller only, no sensor	00	
NH ₃	Ammonia	04	0-250 ppm
Ar	Argon (O ₂ depletion)	23	0-50% O ₂
CO ₂	Carbon dioxide (air quality)	15-2000	0-2000 ppm
CO ₂	Carbon dioxide (compressed)	15-5000	0-5000 ppm
CO	Carbon Monoxide	02	0-100 ppm
CO	Carbon Monoxide	02-250	0-250 ppm
CO nil H ₂	Carbon Monoxide nil H ₂ effect	02nilH2	0-100 ppm
CL ₂	Chlorine	17	0-10 ppm
C ₂ H ₅ OH	Ethanol	07	0-50% LEL
	HCFCs	13	
	HFCs	20	
He	Helium (O ₂ depletion)	23	0-50% O ₂
H ₂ O in air	Humidity (relative)	25	0-100% RH
H ₂	Hydrogen	08	0-50% LEL
H ₂ S	Hydrogen Sulfide	16	0-50 ppm
CH ₄	Methane	05	0-50% LEL
CH ₃ OH	Methanol	07	0-50% LEL
N ₂	Nitrogen (oxygen depletion)	23	0-50% O ₂
NO ₂	Nitrogen Dioxide	14	0-10 ppm
VOCs	Organic Vapors	01	0-1000 ppm
O ₂	Oxygen Leak	22	0-50% O ₂
O ₂	Oxygen Depletion	23	0-50% O ₂
C ₃ H ₈	Propane	06	0-50 % LEL

3.0 Installation

3.1 Monitor Placement

Coverage

Guidelines for placement of diffusion type monitors are based on the reasonable delay for gas to get from the source to the sensor. All monitor sensors combinations are created equal in this regard.

- **For air quality control** of exhaust emissions and accumulations of toxic gases the generally acceptable maximum radius of coverage is 50 feet (15 meters). Approximately 7500 square feet (700 square meters).
- **For leak detection** of combustible gases, ammonia, refrigeration gases the maximum radius is 30 feet (10 meters).

The radius of coverage of any monitor does not extend beyond any obstruction that impedes natural circulation of air. This includes walls, stairs, elevators, shelving with solid fill, tool chests, etc. The sensor must “see” the area of coverage; if not, additional monitors are required.

Mounting Heights

Mounting heights for gas monitors are based on their density, relative to air. There are three groups;

1. **Lighter than air** and will be more concentrated near the ceiling; hydrogen, methane (natural gas), ammonia. Install at 1 to 3 feet from ceiling.
2. **Similar density** to air and will be diluted in air equally at all levels; - carbon monoxide, nitrogen dioxide, hydrogen sulfide, oxygen, carbon dioxide. Install from 3 feet (1 meter) off floor to one half of the ceiling height. For vehicle emissions carbon monoxide sensors combined with nitrogen dioxide sensors are installed at 3 to 5 feet (1 to 2 meters) from the floor when the ceiling height is 7 to 10 feet. If the ceiling height is higher than 10 feet, example- for heavy equipment, the carbon monoxide monitors are installed

at 3 to 5 feet (1 to 1.5 meters) from the floor as per the requirements of the Canada building codes and the nitrogen dioxide monitors should be installed at 50% of the ceiling height and above the vehicle height. If the exhaust pipes of diesel vehicles are below the vehicles, then the nitrogen dioxide monitors should be installed at 3 to 5 feet (1 to 1.5 meters) from the floor. In all cases the monitors must be installed above obstructions blocking circulation of air in front of the monitors; example, maintenance garages in automobile dealerships where tool chests, work tables and storage racks typically line all walls.

- 3. Heavier than air** and will concentrate near the floor; - HFCs, HCFCs, propane, chlorine, most organic vapors (consult Opera). Install 1-2 feet (30cm to 50cm) from floor.

For all types of monitors avoid drafts, obstacles, aerosols, silicones. Place sensors in the center of its coverage area as much as possible.

3.2.1 Wiring Model 6000-A

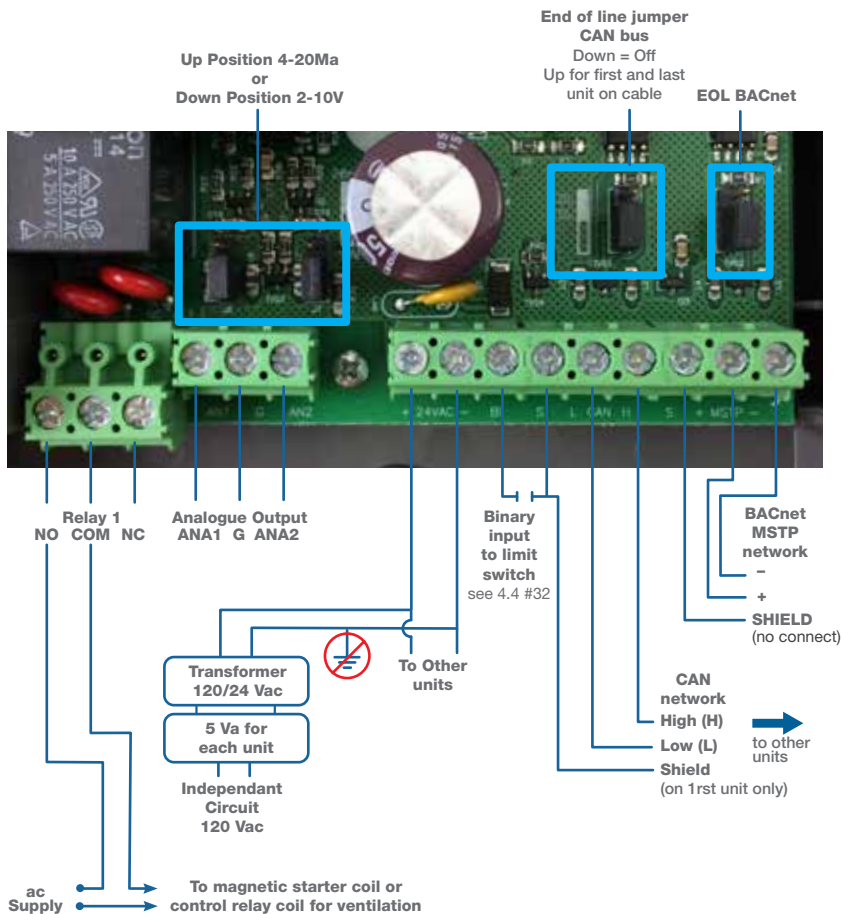

3.2.2 Wiring Model 6000-B

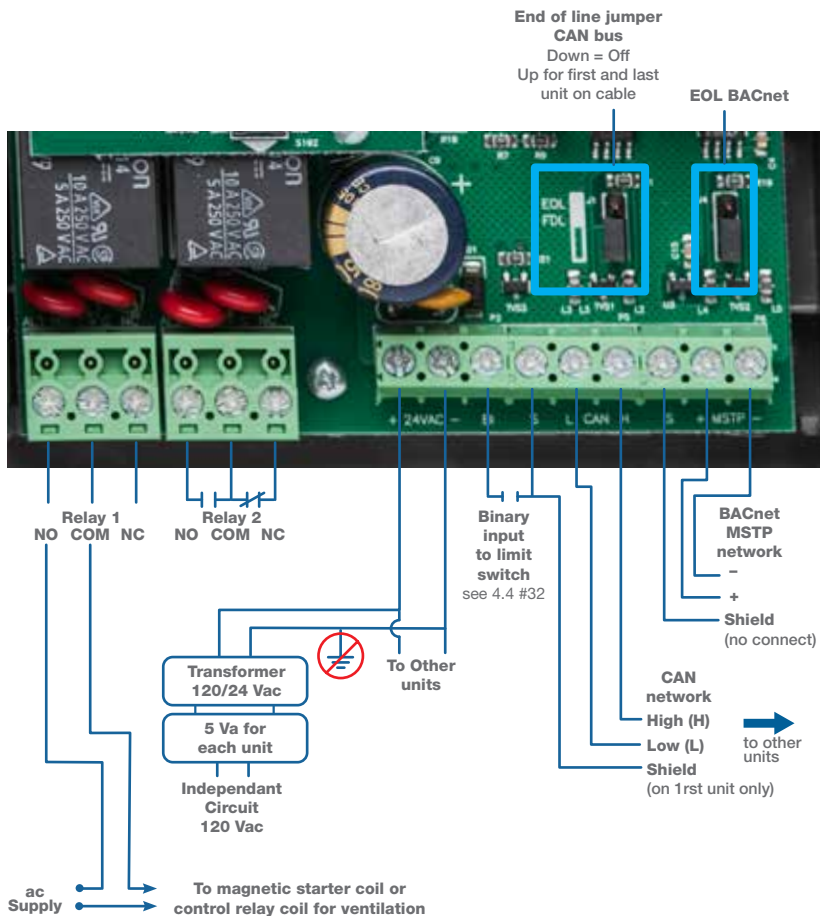

3.3 Installation Check List

Important. All wiring must conform to local building codes, regulations and laws. If the equipment is used in a manner not specified by the manufacturer, the protection provided by the equipment may be impaired.

1. Use ½ inch EMT conduit for all wiring.
2. A switch or circuit breaker must be included in the installation. It must be suitably located and easily reached in a secure location and identified as the disconnect for the “Gas Monitoring System”.
3. Install enclosed 120/24 vac transformer. For the size of transformer allow 5 va for each sensor or controller. Use 18 to 20 AWG two conductor wire. Do not tie the secondary to ground. Connect multiple monitors to one transformer. Ensure that the polarity of the AC connections is the same at each monitor or controller, otherwise communication will not function.
4. Connect relay contacts (usually relay 1) to ventilation system. Use a magnetic starter so that the sensor contacts energize the starter coil and not the fan motor directly.
5. For multiple monitors, inter-connected using the CAN network. Connect a shielded twisted pair cable 22 to 24 AWG from screw “L” and “H” (screw 11 and 12) on one sensor, to the next monitor and continue chain to the last sensor. Maintain the same polarity on each unit. Do not use star, T, or H junctions, only a continuous chain. Make all chain connections at the sensors. Connect shield to “S” on the first sensor or controller only and join shields together at each sensor/controller after the first.
6. Move the end-of-line jumper (the one above terminal 11, 12) to the on position (UP) on the first monitor (or controller) on the chain and the last monitor/controller on the chain. A controller with no sensor module can be located anywhere on the chain. Ensure its EOL jumper is off (down) if it is in the middle. Monitor/controller addresses can be in any location on the chain.
7. Power on the units. They will display the gas type and reading. To verify if monitors are communicating correctly, change setting

no. 56 on one unit. Press → until you reach option 56. Press ↑ to switch from 0 to 1, to turn on the network display. Press ↑ and ← simultaneously to save, then press and hold ← for a few seconds to return home. The unit will display each monitor connected in order of their address. If the unit does not display the others scrolling by, check the following;

- each unit must have a unique address, setting 39, with no duplicates
- end-of-line jumpers are set on units at ends of cable only
- polarity of the communication cable and the 24 Vac is the same on all units
- verify wire connections for shorts, and loose wires, etc.

8. To further test communication, press and hold the up **button** on a monitor for 5 seconds to start manual mode (5 minutes). This will close the relay 1 on that unit and all of the other units on the network. See section 5 to set up a configuration for multiple zones.

For assistance contact Opera Inc.
(see back cover for contact info)

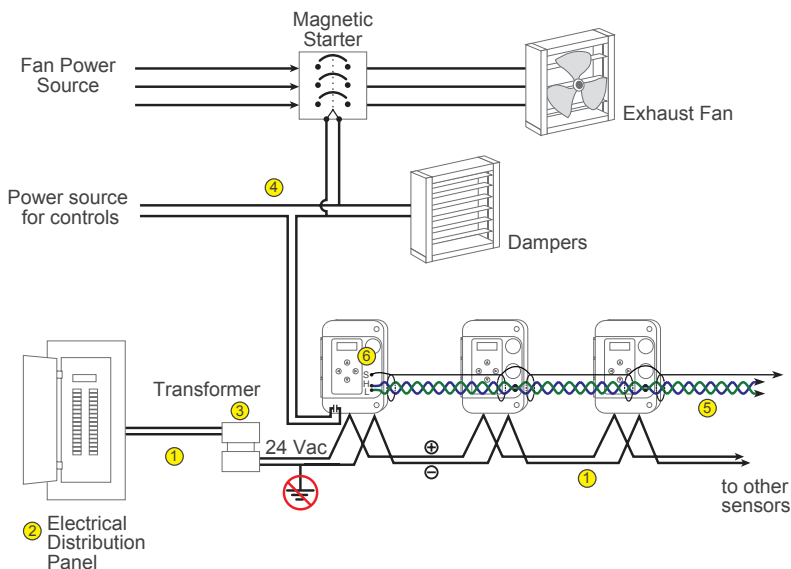

4.0 OPERATION

4.1 Screen Display

The LCD shows the type of gas and the current gas concentration. If two sensor modules are installed, the display will alternate between them.

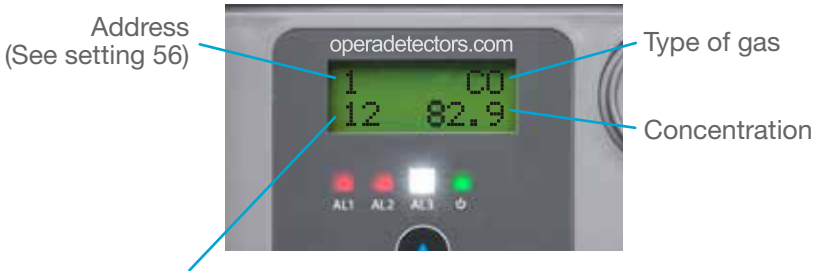

Alarm status

1 indicates alarm 1 on, per settings 0, 1, 2 or if activated by another sensor on the CAN network via setting 36. This is usually the low gas level alarm.

2 indicates alarm 2 on. Per settings 3, 4, 5 or if activated by another monitor on CAN network per setting 37.

3 indicates alarm 3 on. Per settings 6, 7, 8 or if activated by another monitor on CAN network per setting 38. Alarm 3 activates the sounder and strobe.

M indicates manual override mode on. Useful to start ventilation system without the risk of leaving it on too long in cold weather. From the home screen, press and hold ↑ for 5 seconds to start. Then click again to increase time from 5 to 60 minutes. This activates alarm 1 (or 2, and 3 per setting 69) and sends alarm transmit messages (settings 9-17) to other monitor on the CAN

network. The unit will return to automatic operation after the time runs down. To cancel manual mode press ↓ several times to reduce time left to run. It will take a few seconds to stop. “M” also displays when auto-cycle is on. See setting 73.

T indicates alarm 1 on due to high ambient temperature (setting 51). Useful for summer ventilation.

4.2 Default Settings

User settings are factory pre-loaded with default values to facilitate set up and can be changed at any time. Upgrading firmware will not affect user settings.

Alarm thresholds should be set to suit local regulations.

Default values for these are general guidelines only.

4.3 Changing Settings

Press → and ← to move through the settings. If the keypad lock is on then enter the password first. The screen will display the setting number 0, 1, 2, etc. plus the short description (e.g.; AL1 for Alarm 1 and the current setting.)

Press the ↑ or ↓ buttons to increase or decrease the setting. To save, press ↑ and ← buttons at the same time. The word “OK” will appear. If you do not see “OK” and the new value it is because the buttons were not pressed simultaneously. Try again.

4.4 List of Settings Sensor A (upper socket) settings

No.	Name	Description	Range	Default
0	AL1	Alarm 1 threshold, activates relay 1	by sensor	
1	A1Del	Alarm 1 Delay on (seconds)	0-999	30
2	A1Off	Alarm 1 Delay off (seconds)	0-999	20
3	AL2	Alarm 2 threshold, activates relay 2	by sensor	
4	AL2Del	Alarm 2 Delay on (seconds)	0-999	30
5	AL2Off	Alarm 2 Delay off (seconds)	0-999	20
6	AL3	Alarm 3 threshold, sounder	by sensor	
7	A3Del	Alarm 3 Delay on (seconds)	0-999	180
8	A3Off	Alarm 3 Delay off (seconds)	0-999	20
9	A1Tx	Alarm 1 transmit message, CAN network	0-255	1
10	A1Tx	Alarm 1 transmit message, CAN network	0-255	
11	A1Tx	Alarm 1 transmit message, CAN network	0-255	
12	A2Tx	Alarm 2 transmit message, CAN network	0-255	2
13	A2Tx	Alarm 2 transmit message, CAN network	0-255	
14	A2Tx	Alarm 2 transmit message, CAN network	0-255	
15	A3Tx	Alarm 3 transmit message, CAN network	0-255	3
16	A3Tx	Alarm 3 transmit message, CAN network	0-255	
17	A3Tx	Alarm 3 transmit message, CAN network	0-255	

4.4 List of Settings Sensor B (lower socket) settings

No.	Name	Description	Range	Default
18	AL1-B	Alarm 1 threshold, activates relay 1	by sensor	
19	A1Del	Alarm 1 Delay on (seconds)	0-999	30
20	A1Off	Alarm 1 Delay off (seconds)	0-999	20
21	AL2-B	Alarm 2 threshold, activates relay 2	by sensor	
22	A2Del	Alarm 2 Delay on (seconds)	0-999	30
23	A2Off	Alarm 2 Delay off (seconds)	0-999	20
24	AL3-B	Alarm 3 threshold, sounder and strobe	by sensor	
25	A3Del	Alarm 3 Delay on (seconds)	0-999	180
26	A3Off	Alarm 3 Delay off (seconds)	0-999	20
27	A1Tx	Alarm 1 transmit message, CAN network	0-255	1
28	A1Tx	Alarm 1 transmit message, CAN network	0-255	
29	A1Tx	Alarm 1 transmit message, CAN network	0-255	
30	A2Tx	Alarm 2 transmit message, CAN network	0-255	2
31	A2Tx	Alarm 2 transmit message, CAN network	0-255	
32	BiTx	Binary input transmit message when limit switch is closed, CAN bus. See 3.2.1	0-255	0
33	A3Tx	Alarm 3 transmit message, CAN network	0-255	3
34	A3Tx	Alarm 3 transmit message, CAN network	0-255	
35	A3Tx	Alarm 3 transmit message, CAN network	0-255	0

4.4 List of Settings Continued

General settings

No.	Name	Description	Range	Default
36	R1Rx	Receive message to activate relay 1, CAN network	0-255	1
37	R2Rx	Receive message to activate relay 2, CAN network	0-255	2
38	R3Rx	Receive message to activate sounder and strobe CAN network	0-255	0
39	Adr	Monitor identification address, CAN network	0-31	0
40	AnZA	Accessing this option forces analogue output A to low for testing with meter only and no external cables attached. Use up and down arrows to adjust lowest setting (2v or 4 ma) and save		
41	AnSA	Accessing this option forces analogue output A to high for testing with meter only and no external cables attached. Use up and down arrows to adjust highest setting (10v or 20 ma)		
42	AnZB	As option 40 but for output B		
43	AnSB	As option 41 but for output B		
44	Temp	Temperature display enable off/on	0/1	0
45	Aud	Local audio alarm enable on alarm 3	0/1	1
46	BAC	BACnet MSTP mode select 0 = BACnet communication disabled 1 = BACnet communication enabled 2 = BACnet communication enabled and display all sensors on CAN network	0/1/2	0
47	BMA	BACnet MAC address	127	0
48	BBR	BACnet baud rate 0 = 9600 1 = 19200 2 = 38400 3 = 76800	0/1/2/3	3
49	KBL	Keyboard lock, blocks access to options	0/1	0

No.	Name	Description	Range	Default
50	TMod	Temperature modify/calibrate	-9/+9 °C	0
51	ATHi	High temperature alarm limit used for summer ventilation. Alarm 1 is activated when temperature exceeds option. Temp setting 72 deg C/ F will auto convert	0-99 °C 0-210 °F	60 140
52	W/U	Warm up delay disables alarms, seconds	0-255	60
53	BMM	BACnet maximum MAC address when polling for master	0-127	127
54	BDiag	BACnet diagnostic display while accessing this option. In format XXXYYZZ. Where YY is MAC address (in hex) of the monitor that just passed the token to the current one. ZZ is the monitor to which the token was passed to. Example 0305 would display on monitor with MAC address 4		
55	ATLo	Low temperature alarm limit (alarm 3). 0=off		0C/ 32F
56	Net	Enables display on home screen of all monitor on CAN network. 1=0n	0/1	0
57	Ref-A	To select scale and type of gas for sensor A. For model 6020: R507, R23, R134a, R152a, R492a, R404a, R407a, R408a, R410a, R500, R502, R507 For model 6013: R22, R21, R141b, R142b, R401a, R402a, R408a, R409a, R502a For Model 6021: R134a, R125, R404a, R410a, R407a, R407c, R407f, R448a, R449a, R513a, R22, R123, R507, R1234yf, R1234zf	select from list	R507 R22
58	Ref-B	As setting no. 57 but for sensor B (bottom socket)		
59	FlTx	Fault alarm transit message, CAN network	0-255	0

4.4 List of Settings Continued

General settings

No.	Name	Description	Range	Default
60	ADTxA	Analogue drive transmit message, sensor A (top) CAN network	0-255	0
61	AMinA	Analogue drive. Minimum percent of scale for zero output. Sensor A	0-100	0
62	AMaxA	Analogue drive. Maximum percent of scale for full scale output. Sensor A	0-100	100
63	ADRxA	Receive message code to control local analogue output. Sensor A	0-255	0
64	ADTxB	Analogue drive transmit message, sensor B (bottom) CAN network	0-255	0
65	AMinB	Analogue drive. Minimum percent of scale for zero output. Sensor B	0-255	0
66	AMaxB	Analogue drive. Maximum percent of scale for full scale output. Sensor B	0-100	100
67	ADRxB	Receive message code to control local Analogue output B	0-255	0
68	Baud	Baud rate for CAN network Maximum network wire length is 1500 feet at rate 0 and 3000 feet at rate 1 Use rate 0 with model 5000	0-1	0
69	Man	Manual override from home screen activates alarms 1, 1+2, 1+2+3. See section 4.1	1-3	1
70	BDI	BACnet device instance Enter part 1 (1000 to 4,194,303) Press right arrow Enter part 2 (0 to 999)	0-4,194,303	60,000 +BMA
71	Light	1 = backlight always on 0 = on when keyboard activated	0-1	0
72	°C/°F	Display 0 = degrees C, 1 = degrees F Will also convert settings 51 and 55	0-1	0
73	Cycle	Automatic cycle timer Alarm 1 00C = total Cycle time in minutes Press right arrow 00R = Run time in minutes	0-255	00/00
74	Age	Sensor module A age in days Press enter to display Sensor B		0

No.	Name	Description	Range	Default
75	VSD A	Variable Speed Drive logic Analogue output A Combines analogue outputs over CAN bus. See options 60-66 0= highest reading wins 1= sensor readings are averaged 2= auto ramping increases analogue output by one-minute intervals on alarm 1 and decreases when below alarm.	0/1/2	0

4.5 Sequence of Operation

1. Monitors are pre-loaded with options for normal operation and can be changed by the user at any time via the key pad.
2. On power-up the display will show the software revision number and the Warm-Up Timer will count down (setting 52, default 1 minute). Relays are inactive during this time. Press any button to cancel the warm-up period.
3. The display will show the gas type and the current gas concentration. For dual-monitors the display will alternate between the two sensor modules showing the gas type and concentration of each. If the network display option is turned on (option 56) the display will show each monitor that is connected via the CAN network, its address, gas type and concentration. Monitor will display for 3 seconds and then cycle to the next, lowest address to the highest and then start again.
4. If the gas level rises above the Level One Set Point then the Delay-On Timer will start. The time setting range is from 1 to 999 seconds. If the gas level drops below level one the timer will reset and start over the next time it goes over.
5. If the gas level stays above the Alarm 1 Level for the set time the relay 1 on-board will energise, and remain energised as long as the gas remains above the alarm setting. The bottom left corner of the display will indicate a 1 and the alarm 1 LED will light up. In

addition, the Alarm 1 Transmit Message (default is 1) will be sent to all monitors and controllers via the CAN network.

6. All monitors or controllers on the CAN network with a Relay 1 Receive Message (setting 36) = 1 will energise their on-board relay 1, and display a 1 in the bottom left hand corner of their display.
7. When the current gas concentration drops below the Alarm 1 set point, the Delay-Off time will start. The timer will clear if the gas rises above the alarm setting.
8. When the Delay-Off Timer times out the relay 1 will de-energise, the Alarm 1 LED will turn off and the Relay 1 Transmit message will stop being sent, thereby de-energising relays on other units.
9. If the temperature exceeds the Hi Temperature Alarm, setting 51, relay 1 will activate, the Alarm 1 LED will turn on and the Alarm 1 Transmit message will be sent via the CAN network to other sensors and controllers. When temperature drops, the alarm 1 will be turned off and the Alarm 1 Transmit message will stop being sent.
10. If the gas level rises to the Alarm Level 2 setting, then the Level 2 Delay-On Timer will begin, and after timing-out the on-board relay 2 will activate (for models 60xx-B only) the Alarm 2 LED will turn on, the Relay 2 Transmit message (default = 2) will be set out on the CAN network activating remote units with that same Relay 2 Receive message (option 37). Note that all 3 alarms operate independently and can be higher or lower than the others.
11. When the current gas concentration drops below the Alarm 2 setting for longer than the Alarm 2 Off-Delay Setting the relay 2 will turn off, the Relay 2 LED will turn off, and the Relay 2 Transmit message will stop being sent on the CAN network.
12. When the gas concentration rises above the Alarm Level 3 setting for more than the Alarm 3 Delay-On timer the audible alarm will sound, the LED strobe flasher will start (if enabled; setting 45), a 3 will appear in the bottom left corner of the display, and the Alarm 3 Transmit message (default 3) will be sent to other sensors or controllers. They can be silenced by pressing any button.

13. When the gas concentration drops below the Alarm 3 set point for longer than the Alarm 3 Delay-Off setting then the audible alarm and strobe flasher will stop and the Alarm 3 Transmit message will stop being sent on the CAN network.
14. On a sensor fault condition, the units will transmit the Fault Transmit Message, option 59, to other monitors or controllers.
15. Manual Over-ride mode is available to test relay functions and to activate ventilation. From the home screen press and hold the up arrow for 5 seconds. Press the up arrow to increase the timer by 5 minutes per click up to 60 minutes. The screen will display MAN 5 and timer will energise relay 1 and send the Alarm 1 Transmit Message on the CAN network. After the time runs down the unit will return to automatic operation. To cancel, press the down arrow several times to reduce the timer to zero and return to normal operation. To activate Alarm Level 2 or 3 as well with this procedure, set option 69 to 2 or 3.

This sample sequence of operation shows the operation of a basic network for one zone. See the Operation Manual section 4 Operation to see how to change settings and section 5 Configurations for setting up multiple zones.

5.0 Network Configuration

5.1 Using CAN Network with a Central Controller

A model 6000 controller serves as the central connection point for the ventilation system. Model 60XX gas monitors transmit alarm commands to the central controller.

A controller will display up to 32 monitors on the network. It also displays their address, gas type, gas concentration, and alarm status for each. Two relays on board can be configured for different levels of gas or to operate different ventilation systems, zones or groups. If more than two relays are needed add a model 6100 Relay Expansion Unit which has four additional relays.

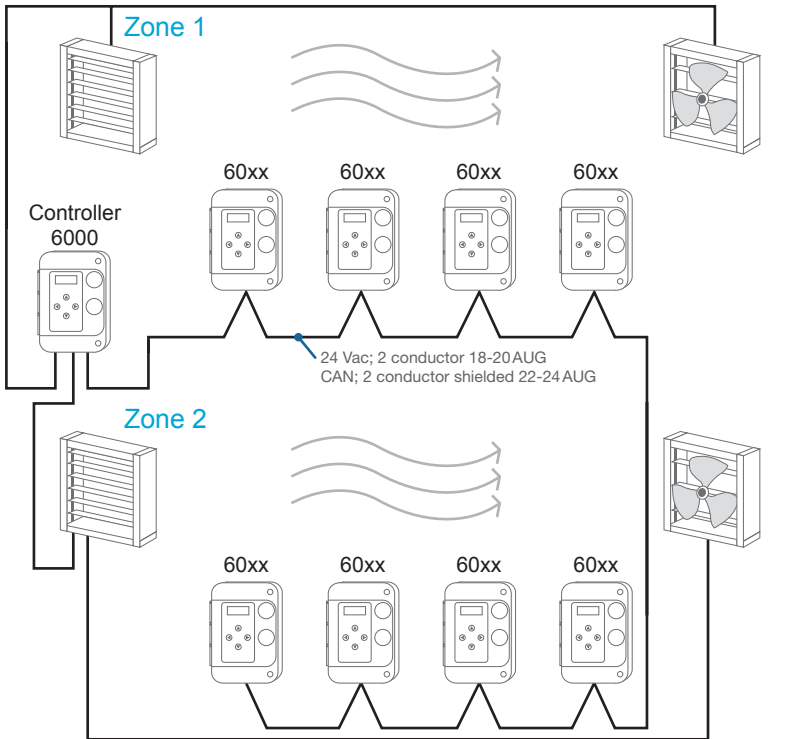

5.2 Using CAN Network with No Central Controller (master/slave operation)

One of the 60XX series monitors can be used as the controller. It can activate the ventilation for all the sensors, or a group. The use of a dedicated controller is optional; - to add a display in some specific location, such as before entering a mechanical room or to interface with several fan starters located in one place. Starters and air dampers are connected to the sensor closest to it in each zone. Starters and air dampers are connected to the sensor closest to it in each zone.

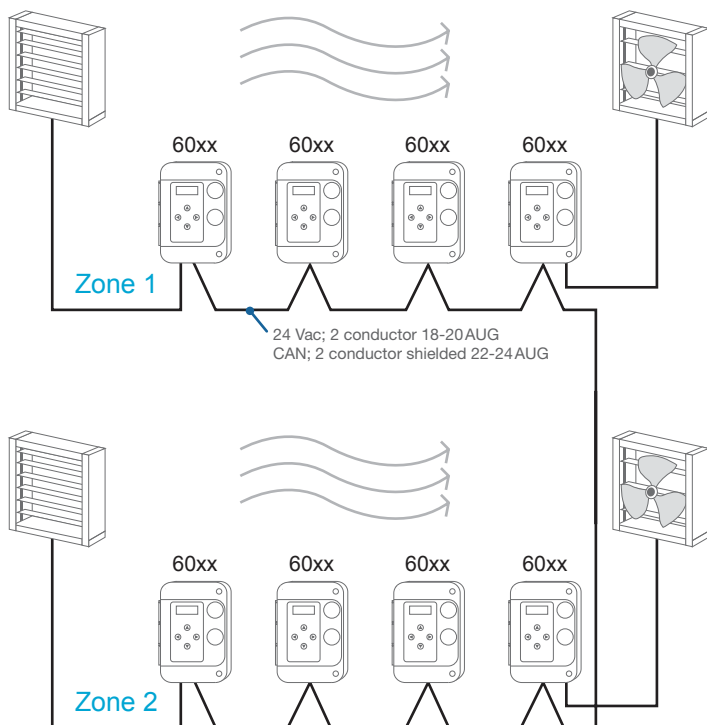

5.3 Default Configuration

Monitors are shipped pre-loaded with default settings which can be changed in the field to suit the desired sequence with simple keypad input. When a monitor goes into alarm level 1, 2 or 3 it activates its relays and transmits a message to other sensors to activate their relays also. Alarm 3 message are transmitted by default, but the receive option 38 defaults to 0 so the audible alarms and strobe operate locally and not everywhere. The ventilation system can be connected to any of the relays (usually level 1 relay). The default configuration for one ventilation zone. Default alarm settings are for general guidance and testing and should be set to suit local regulations.

5.4 Creating Zones or Groups

To control multiple zones on the same network, set the transmit message on each sensor to different messages for different zones. The default transmit messages are 1, 2, 3 for alarm levels 1, 2, 3 for zone 1.

For zone 2 monitors set transmit messages to 4, 5, 6

For zone 3 monitors set messages to 7, 8, 9, and so on

5.5 Addresses

Set each monitor and controller to a different address (setting 39). 1, 2, 3, 4 etc. It is important to have no duplicates on the same network cable.

5.6 Output Relays

Relay number 1 and 2 will activate if the gas on that monitor goes into alarm level 1, or 2. It will also activate when it sees it's receive code (setting 36, 37) on the network, sent by other sensors. If more than 2 relays are needed, add a model 6100 Relay Expansion Unit which has 4 additional relays. It can be installed anywhere on the CAN network.

A model 6000 basic controller has no sensors on board so the relays will only activate if it sees it's receive codes on the network. The 6000 controller could control two zones via its two relays. When no controller is used, the master monitor(s) needs to be a member of the group it is controlling.

6.0 Maintenance Guide

All monitors are shipped from the factory pre-calibrated. To maintain accuracy and conformity with standards it is essential that they be calibrated by a qualified technician once or twice per year, depending on the application.

6.1 Calibration Procedure

Use certified precision gas mixtures to adjust the sensitivity of the sensor due to normal aging and guarantee that the designed alarm set points are respected. So-called “automatic calibration” or “self-test” will not provide this level of security. Only use gas concentrations within the specified range of the sensor.

6.2 Calibration Procedure for Electro-chemical and Catalytic sensors (CO, NO₂, CH₄, NH₃, CL₂)

1. Use certified bottled calibration gas mixtures only. Ensure that monitors are powered on for a minimum of the break-in period for the sensor. For electro-chemical type sensors, this is only a few minutes.
2. Press the right arrow to enter settings
3. Press the ↑ and → at the same time to enter calibration mode. SAZ (sensor A zero) will display and show the current gas reading on the top line
4. Inject bottled zero gas into first sensor. Use a flow rate of 0.1 LPM to 0.5 LPM. The gas fitting to sensor should have a small outlet hole. If not, the pressure will increase and distort the reading (high).
5. Adjust gas reading to zero with the ↑ and ↓ buttons
6. Press ↑ and ← at the same time to save.
7. Press → The display will show SAS (sensor A span) and the current gas reading

8. Inject bottled span gas into first sensor and wait until the gas reading stops going up. The span gas used must be within the range of sensor's scale.
9. Adjust the reading up or down to match the concentration in the bottle
10. Press ↑ and ← at the same time to save
11. If second sensor installed press → and repeat steps 4 to 10 for sensor B
12. Press left arrow several times to return to settings and home.

Calibration Procedure for Refrigerant (type 13, 20) and VOC (type 01) sensors

1. Use certified bottled calibration gas mixed with air only, not nitrogen. Ensure that monitors are powered on for a minimum of the break-in period for the sensor. For these types sensors, this is two days.
2. Inject bottled span gas
3. Adjust the blue potentiometer on the module to set the sensor reading displayed to that of the bottle mix. Do not change the factory calibration constants in calibration mode as above.
4. Remove span gas mix and supply air. Sensor will return to zero.
5. If sensor does not return to zero, it needs replacement

For assistance contact Opera Inc.
(see back cover for contact info)

7.0 BACnet Network Configuration

For instructions on changing settings see section 4.3

Setting 46	Bacnet Mode select 0 = communication disabled 1 = communication enabled 2 = communication enabled and display all monitors on CAN network	0, 1, 2	Default 0
Setting 47	BMA MAC address	0-127	0
Setting 48	Baud rate	0 = 9600 1 = 19200 2 = 38400 3 = 76800	3
Setting 53	Max Master	0-127	127
Setting 54	Diagnostic tool to test MSTP communication. Format XXXXYYZZ where YY= ID of device that passed token to current sensor and ZZ = ID of device that received token.		
Setting 70	Device ID	4,194,303	60,000+BMA

Ventilation Controlled by BACnet Building Automation

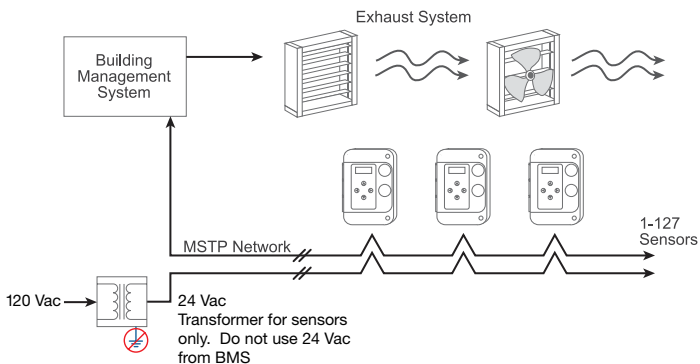

Object Table

Type and Instance	Object Name	Object Property	Parameter
AV0	gas reading 1	Present value (R)	Gas reading local sensor A
AV1	gas reading 2	Present value (R)	Gas reading local sensor B
AV2	Ambient temperature	Present value (R)	Temperature in celsius
BI 0	Input 1	Present value (R)	Auxiliary input state 0/1
BO 0	Relay 1	Present value (R/W)	Relay 1 status on 0/1
BO 1	Relay 2 or alarm 2	Present value (R/W)	Relay 2 or alarm 2 status 0/1
BO 2	Alarm 3	Present value (R/W)	Alarm 3 Indicator status 0/1
AV XXX	Gas reading XXX	Present value (R)	Gas reading remote sensors if setting 46=2

X = sensor 1 (top) or 2 (bottom),

YY = CAN Address

Analogue value for each gas reading will display description of gas type and scale

Ventilation Controlled directly by Gas Sensors

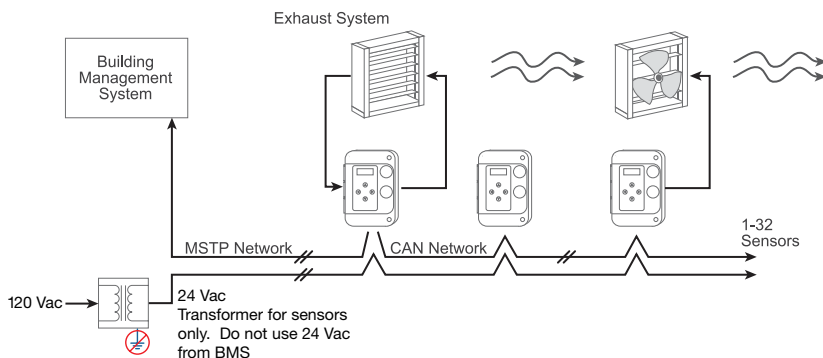



Installation Guide PDF



User Manuel PDF



697 Meloche St
Dorval, Quebec
Canada H9P2S4

514-556-3013
info@detecteursopera.com
www.operadetectors.com